

7. 电器/Electric Device

序号/ No.	名 称 / Designation	页 码 /Page No.
7,01	过电压报警装置/Over Voltage Alarming Device	1
7,02	09款电气控制系统(VDO)/Electric Control System(VDO)	2
7,03	HW电气接线盒铭牌/Nameplate	3
7,04	电器装置/Electric Equipment	4
7,05	底盘电器 1/Chassis Electric Device 1	6
7,06	底盘电器 2/Chassis Electric Device 2	7
7,07	HOWO车前照灯/Headlamp	8
7,08	工作灯/Working Lamp	10
7,09	牵引车侧标志灯/Side Marker Lamp	11
7,10	带侧标志灯的组合后灯/Rear Lamp	12
7,11	蓄电池(165安-时)/165 AH Battery	13
7,12	新型电瓶箱/Battery Box	14
7,13	车速传感器/Vehicle Speed Sensor	15
7,14	挂车七孔插座--24N型/Trailer seven hole socket (24N)	16
7,15	尾灯电线/Rear Lamp Wireness	17
7,16	轮、轴间差速锁电线束/Diff. Lock Wireness	18
7,17	车架电线束/Chassis Wireness	19
7,18	起动机负极至后分线盒搭铁线/Wireness	20
7,19	起动机电线束/Starter Wireness	21
7,20	HW7E牵引车底盘电线束/Chassis Wireness	22
7,21	HW7E驾驶室电线(VDO系统)/Cab Wireness (VDO System)	23
7,22	主副油箱转换开关/Main and Auxiliary Fuel Tank Change-over Switch	25
7,23	国2车型起动附加电线束/Starter Auxiliary Wireness	26

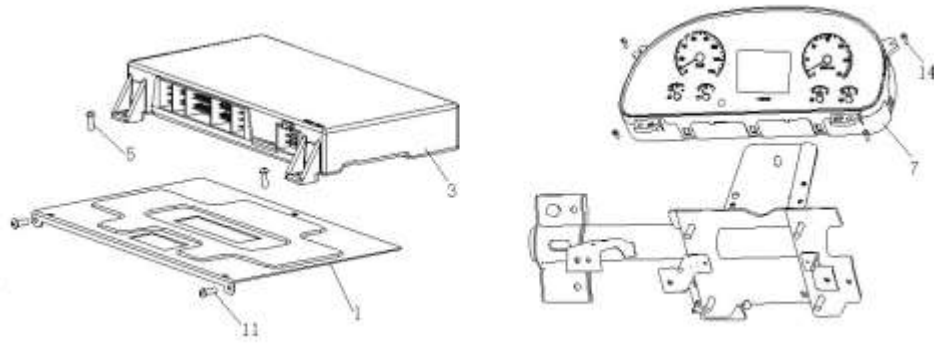

7.02 09款电气控制系统 (VDO)/Electric Control System (VDO)

序号 No.	零部件图号 Part No.	名称	Part Name	数量 Qty	备注 Remark
1	AZ9724580002	CBCU安装板	CBCU Plate	1	
2	Q2714216	十字槽盘头自攻螺钉	Screw	2	
3	WG9716580023	中央控制单元 (CBCU)	CBCU	1	
5	Q2140512	十字槽盘头螺钉	Screw	3	
6	Q40105	平垫圈	Washer	3	
7	WG9716580025	组合仪表 (CMIC)	CMIC	1	
9	Q2714816	十字槽盘头自攻螺钉	Screw	4	
10	Q40105	平垫圈	Washer	4	
11	Q2714216F31	十字槽盘头自攻螺钉	Screw	2	
12	Q340B05	1型六角螺母	Nut	3	
13	Q340B05	1型六角螺母	Nut	3	
14	Q2714816F31	十字槽盘头自攻螺钉	Screw	4	

7.03 HW电气接线盒铭牌 (英文)/Nameplate

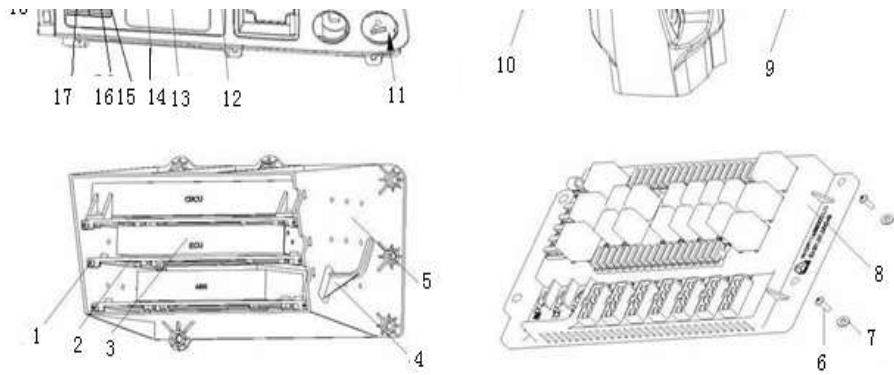

7.04 电器装置/Electric Equipment

序号 No.	零部件图号 Part No.	名称	Part Name	数量 Qty	备注 Remark
4	WG9725584026	线束固定夹	Wireness clip	1	
5	WG9725584029	ECU安装箱	ECU box	1	
5a	Q150B0825	六角头螺栓	Screw	5	
5b	Q40108	平垫圈	Washer	5	
5c	Q40308	弹簧垫圈	Spring washer	5	
5d	Q340B08	1型六角螺母	Nut	5	
6	Q2140635	盘头螺钉	Screw	4	
7	Q40106	平垫圈	Washer	5	
8	WG9716580021	电气接线盒总成	Wire connecting box	1	
8,01	WG9725584015	5A片式熔断器 (C型)	Fuse-5A	8	
8,02	WG9725584016	10A片式熔断器 (C型)	Fuse-10A	11	
8,03	WG9725584017	15A片式熔断器 (C型)	Fuse-15A	13	
8,04	WG9725584018	20A片式熔断器 (C型)	Fuse-20A	6	
8,05	WG9725584019	25A片式熔断器 (C型)	Fuse-25A	3	
8a	Q2140610	十字槽盘头螺钉	Screw	1	
8b	Q2140512	十字槽盘头螺钉	Screw	2	
8c	Q40105	平垫圈	Washer	2	
10	WG9130583117	组合开关(转向柱上)	Combined switch	1	
10a	Q2140512	十字槽盘头螺钉	Screw	3	
10b	AZ9725580030	橡胶堵盖	Rubber plug	1	

7.04 电器装置/Electric Equipment

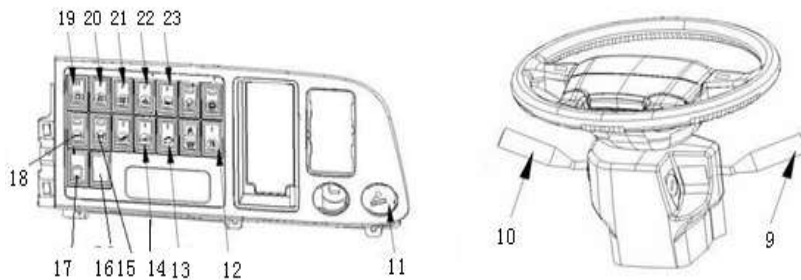

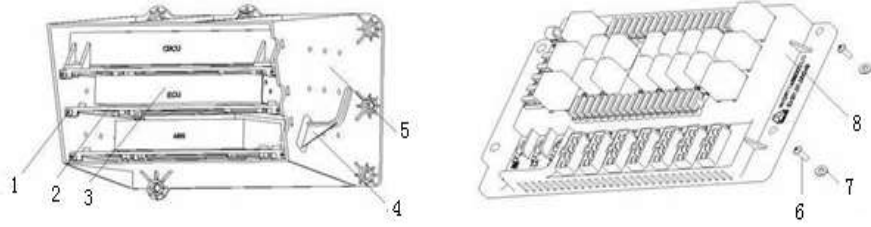

7.04 电器装置/Electric Equipment

序号 No.	零部件图号 Part No.	名称	Part Name	数量 Qty	备注 Remark
11	WG9100580142	24V点烟器	Cigarette light (24V)	1	
14	WG9719582007	工作灯开关	Working lamp switch	1	
15	WG9719582012	轴差开关	Inter axle diff.lock switch	1	
16	WG9900580021	盖板	Plate	7	
17	WG9719582054	MCS旋钮	MCS Knob	1	
18	WG9719582011	轮差开关	Inter wheel diff.lock switch	1	
19	WG9719584011	灯光开关	Light switch	1	
20	WG9719584012	前雾灯开关	Front fog lamp switch	1	
21	WG9719584013	后雾灯开关	Rear fog lamp switch	1	
22	WG9719584004	危急报警开关	Emer. alarming switch	1	
23	WG9719584015	喇叭开关	Horn switch	1	
	WG9725580005	诊断接口外壳	Cover for diagnosis joint	1	
	WG9725584001	40A常开式继电器	40A Relay (normally on)	3	
	WG9725584002	20A常开式继电器	20A Relay (normally off)	10	

7.05 底盘电器 1/Chassis Electric Device 1

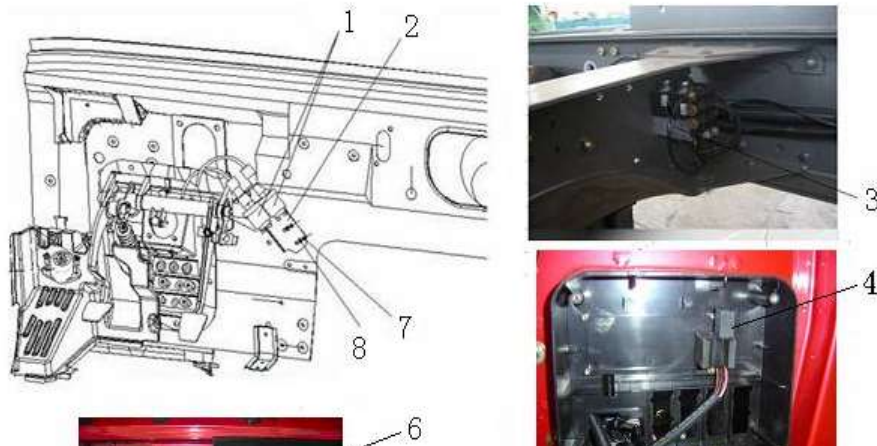



7.05 底盘电器 1/Chassis Electric Device 1

序号 No.	零部件图号 Part No.	名称	Part Name	数量 Qty	备注 Remark
1	WG9727710002	电子式气压传感器	Air pressure sensor	2	
2	WG9725710004	支架	Bracket	1	
3	WG9719710004	电磁阀(P99接头)	Solenoid valve	3	
4	WG9725584002	20A常开式继电器	20A relay (normally on)	1	
5	WG9725580006	100A保险装置	100A fuse	1	
6	WG9718710002	盆形电喇叭	Electric horn	1	
7	Q2140620F31	十字槽盘头螺钉	Screw	2	
8	Q40306	弹簧垫圈	Spring washer	2	
9	Q1460825	组合件	Combination screw	1	
10	Q340B08	1型六角螺母	Nut	1	
11	WG9100710004	气压信号灯开关	Switch - air signal lamp	2	
12	Q150B08190	六角头螺栓	Screw	2	
13	Q40308	弹簧垫圈	Spring washer	2	
14	Q340B08	1型六角螺母	Nut	2	
15	Q2140410	十字槽盘头螺钉	Screw	1	
16	Q40304	弹簧垫圈	Spring washer	1	
17	Q40104	平垫圈	Washer	1	
18	Q150B0620	六角头螺栓	Screw	2	
19	Q40306	弹簧垫圈	Spring washer	2	
20	Q40106	平垫圈	Washer	2	
21	Q340B06	1型六角螺母	Nut	2	

7.06 底盘电器 2/Chassis Electric Device 2



7.07 HOWO车前照灯/Headlamp					
序号	零部件图号	名称	Part Name	数量	备注
No.	Part No.			Qty	Remark
1	WG9719720001	左前照灯总成	Headlamp ass. -left	1	
4	WG9719720002	右前照灯总成	Headlamp ass. -right	1	
4a	Q150B0822	六角头螺栓	Screw	2	
4b	Q150B0816	六角头螺栓	Screw	2	
4c	Q340B08	1型六角螺母	Nut	4	
4d	Q40108	平垫圈	Washer	8	
4e	Q40308	弹簧垫圈	Spring washer	4	
4f	Q2140620	十字槽盘头螺钉	Screw	4	
4g	Q40106	平垫圈	Washer	4	
4h	Q40306	弹簧垫圈	Spring washer	4	
6	AZ9718720002	前照灯安装板	Plate	2	
6a	Q150B0820	六角头螺栓	Screw	6	
6b	Q40308	弹簧垫圈	Spring washer	6	
8	AZ9718720003	连接板	Plate	2	
8a	Q150B0616	六角头螺栓	Screw	4	
8b	Q340B06	I型六角螺母	Nut	4	
8c	Q40106	平垫圈	Washer	4	
8d	Q40306	弹簧垫圈	Spring washer	4	
8e	Q40108	平垫圈	Washer	6	
8f	Q40308	弹簧垫圈	Spring washer	6	
8g	Q150B0820	六角头螺栓	Screw	6	

7.07 HOWO车前照灯/Headlamp



7.07 HOWO车前照灯/Headlamp

序号	零部件图号	名称	Part Name	数量	备注
----	-------	----	-----------	----	----

翘板开关 组合开关
Rocker switch Combination switch

7.21 HW7E驾驶室电线(VDO系统)/Cab Wireness (VDO System)

序号 No.	零部件图号 Part No.	名称	Part Name	数量 Qty	备注 Remark
2	AZ9727770001	EGR驾驶室电线束(VDO系	Cab wireness	1	
3	Q41205	外锯齿锁紧垫圈	Washer	3	
4	Q68620	单管夹片	Clip	1	
5	Q150B0616	六角头螺栓	Screw	1	
6	Q40306	弹簧垫圈	Spring washer	1	
7	Q340B06	I型六角螺母	Nut	1	
8	WG9725584005	120Ω电阻	120Ω Resistance	2	
11	WG1642110018	保护条	Strip	10	
15	WG9725584031	过线箱体	Box	1	
17	Q150B0825	六角头螺栓	Screw	4	
18	Q340B08	I型六角螺母	Nut	4	
19	Q40108	平垫圈	Washer	8	
20	Q40308	弹簧垫圈	Spring washer	4	
21	WG9725584032	过线盒盖	cover	1	
23	Q2140420	十字槽盘头螺钉	Screw	4	
24	AZ9719770047	橡胶过孔护圈(Φ50)	Protect ring	1	
26	WG9100770392	分线箱体	Distributing box	1	
29	179100770391	配电箱	Distributing box	1	
36	Q2762995	开槽半沉头自攻螺钉	Screw	3	
37	WG9100770394	分线盒盖	Distributing box cover	1	

7.21 HW7E驾驶室电线(VDO系统)/Cab Wireness (VDO System)

